

Cuisinart®

INSTRUCTION BOOKLET



**Classic Series 14-Cup (3.5 L)
Food Processor**

DFP-14NC Series

For your safety and continued enjoyment of this product,
always read the instruction book carefully before using.

CAPACITY CHART

Recommended work bowl capacity for various foods

FOODS	CAPACITY
Chopped and Puréed Fruit and Vegetables	3 cups (750 ml)
Chopped or Puréed Meat, Poultry, Fish or Seafood	2¼ pounds (1.03 kg)
Bread Dough	2½ pounds [1.13 kg (5 cups) flour, yielding two 1¼ pound loaves (625 g)]
Nuts for Nut Butters	3 cups (750 ml)
Sliced or Shredded Fruit, Cheese, or Vegetables	14 cups (3.31 L)
Cake Batter	4 pounds (1.8 kg) [(five 8-inch layers) 20 cm]
Cookie Dough	3½ pounds [136 kg (90 cookies)]

IMPORTANT UNPACKING INSTRUCTIONS

This packing contains a Cuisinart® Food Processor, and these standard parts for it: metal chopping blade, slicing disc and shredding disc, detachable stem for discs and spatula.

CAUTION: THE CUTTING TOOLS HAVE VERY SHARP EDGES. To avoid injury when unpacking the parts, please follow these instructions:

1. Place the box on a low table or on the floor next to the kitchen counter or table where you plan to keep the food processor. Be sure the box is right-side up.
2. Remove the cardboard panel and the instruction material with plastic spatula.
3. You will see a rectangular block of plastic foam that holds the processor parts each fitted into a cavity in the foam.

4. The detachable stem (A) for the discs is in a cavity at one short side of the foam block. Remove it first.
5. The slicing disc (B) is on one long side and the shredding disc (C) on the other. Slide them out of their grooves **WITH GREAT CARE; THE BLADES ARE SHARP.**
6. Now only the work bowl cover (D) and the pusher assembly (E) remain in the foam block. Grasp the edge of the work bowl cover and lift it straight up. Lift the pusher assembly straight up by following.
7. Lift out the foam block.
8. The machine base and work bowl with metal blade are at the bottom of the box.
CAREFULLY REMOVE THE METAL BLADE BY GRASPING THE CENTER WHITE HUB AND LIFTING IT STRAIGHT UP. NEVER TOUCH THE BLADES, WHICH ARE RAZOR SHARP.
9. Lift the bowl straight up.
10. You will see the machine base remain at the bottom of the box. Remove the base by grasping the base housing with both hands and lifting it straight up. Place the base on a counter or table and read the instructions thoroughly before using the machine.
11. Save the shipping cartons and plastic foam blocks. You may want to use them in shipping the processor at a later date.

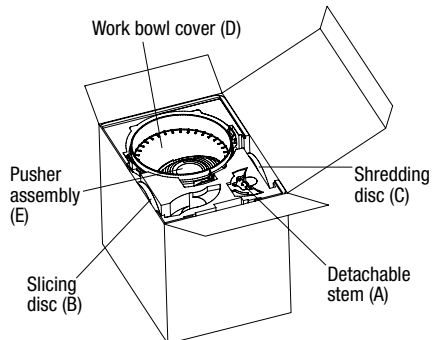

IMPORTANT SAFEGUARDS

Always follow these safety precautions when using this appliance:

Getting Ready

1. READ ALL INSTRUCTIONS.
2. **Unplug from outlet when not in use, before putting on or taking off parts, and before cleaning. To unplug, grasp plug and pull from electrical outlet. Never pull cord.**
3. Blades are sharp! Handle them carefully.
4. Do not use outdoors.
5. Do not let cord hang over edge of table or counter, or touch hot surfaces.
6. Do not operate any appliance with damaged cord or plug, or after appliance has been dropped or damaged in any way. Return appliance to the nearest authorized service facility for examination, repair or electrical or mechanical adjustment.

Operation

1. Do not use pusher assembly if sleeve becomes detached from pusher.
2. Keep hands as well as spatulas and other utensils away from moving blade or discs while processing food, to prevent possibility of severe personal injury or damage to Classic Series 14-Cup Food Processor. A plastic scraper may be used, but must be used only when the motor is stopped.
3. Avoid contact with moving parts. Never push food down by hand when slicing or shredding. Always use pusher, or injury could occur.
4. Make sure motor has completely stopped before removing cover. If machine does not stop within 4 seconds when you turn the cover, call 800-472-7606 for assistance. Do not use machine.
5. Never store the blade or discs on the motor shaft. To reduce the risk of injury, the blade or discs should not be placed on the shaft except when the bowl is properly locked in place and the processor is in use. Store the blade and discs as you would sharp knives, out of reach of children.
6. Be sure cover is securely locked in place before operating food processor.
7. Never try to override or tamper with cover interlock mechanism.

Cleaning

1. To protect against risk of electrical shock, do not put base in water or other liquids.

General

1. Close supervision is necessary when any appliance is used by or near children.
2. Do not operate this, or any other motor-driven appliance, while under the influence of alcohol or other substances that affect your reaction time or perception.

3. This food processor is built to our professional standards. It is UL listed for household use. Use it only for food preparation as described in the accompanying recipe book.
4. The use of attachments not recommended or sold by Cuisinart may cause fire, electrical shock, personal injury or damage to your Classic Series 14-Cup (3.5 L) Food Processor.
5. To avoid possible malfunction of work bowl switch, never store processor with pusher assembly in locked position (activation position).
6. Maximum rating of 6.0 amperes is based on attachments that draw the greatest current. Other recommended attachments may draw significantly less current.
7. Do not operate your appliance in an appliance garage or under a wall cabinet. **When storing in an appliance garage always unplug the unit from the electrical outlet.** Not doing so could create a risk of fire, especially if the appliance touches the walls of the garage or the door touches the unit as it closes.

TABLE OF CONTENTS

Capacity Chart	2
Important Safeguards	3
Features and Benefits	4
The Parts (Diagram).....	4
Practicing With Food.....	5
Removing Processed Food.....	5
Techniques for Chopping and Puréeing	5
Techniques for Kneading Yeast Dough	7
Problems & Solutions with Typical Dough.....	9
Preparing Food for Slicing and Shredding	10
Practicing Slicing and Shredding.....	10
Removing Sliced or Shredded Food.....	11
Techniques for Slicing and Shredding	11
Slicing Meat and Poultry	11
Slicing and Shredding Cheese.....	11
If You Have a Problem	12
Some Technical Data.....	12
Cleaning and Maintenance	13
For Your Safety	13
Warranty	26

SAVE THESE INSTRUCTIONS FOR HOUSEHOLD USE ONLY NOTICE

This appliance has a polarized plug (one blade is wider than the other). As a safety feature, this plug will fit in a polarized outlet only one way. If the plug does not fit fully in the outlet, reverse the plug. If it still does not fit, contact a qualified electrician. Do not attempt to defeat this safety feature.

FEATURES AND BENEFITS

The machine includes:

1. Housing base with a vertically projecting shaft and two large control levers.
2. 14-cup (3.5 L) work bowl.
3. Cover with a large feed tube.
4. Pusher assembly that slides over the feed tube.

The pusher assembly has 2 parts:

- a. A small, removable, clear pusher that fits into a small center-located feed tube. This tube is for narrow food like carrots, for adding liquid, and for continuous feeding of small, hard food like garlic.
 - b. A large pusher.
5. Plastic spatula.
 6. Sharp metal chopping/mixing/dough blade. The metal blade chops raw and cooked fruits, vegetables, meat, fish and cheese to the exact consistency you want – from coarse to fine, even to a purée. You control the texture. It chops nuts, makes nut butters, mayonnaise and sauces, and mixes tender, flaky pastry. The metal blade also handily mixes cakes, frostings, cookies, quick breads, muffins, and biscuits.
 7. Serrated slicing disc. The slicing disc makes beautiful whole slices with no torn edges. It slices whole fruits and vegetables, cooked meat, semi-frozen raw meat and loaves of bread.
 8. Shredding disc. The shredding disc processes most firm and hard cheeses into long, attractive shreds. It also shreds vegetables like potatoes, carrots and zucchini, and it processes nuts and chocolate to a grated texture.
 9. Detachable stem that fits both discs. The detachable stem fits both discs, making storage easy in limited space.
 10. BPA free (not shown)
All materials that come in contact with food are BPA free.

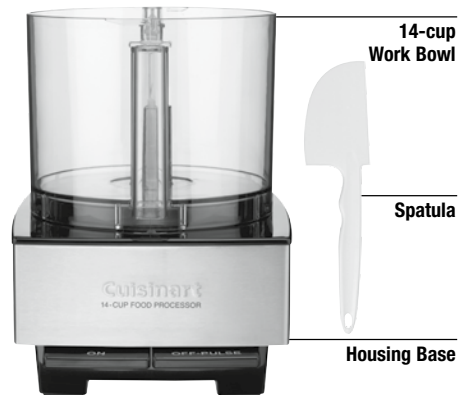
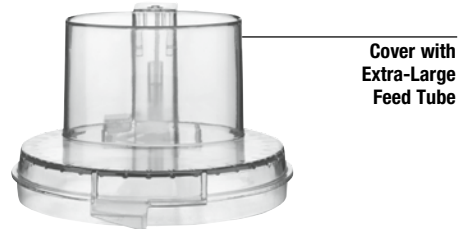
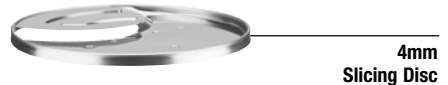
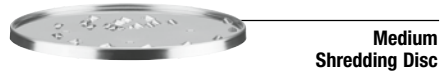
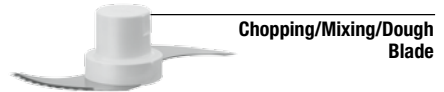

PRACTICING WITH FOOD

Try practicing with some food before you process food to eat. A zucchini or carrot is a good choice. First cut it into 1-inch (2.5 cm) pieces.

Insert the metal blade and put the pieces in the work bowl. Put on the cover and the pusher assembly; press the pusher assembly down to lock it into place. Press and release the OFF/PULSE lever two or three times and see what happens. Each time the blade stops, let the pieces drop to the bottom of the bowl before you pulse again. That puts them in the path of the blade each time the motor starts.

Using the pulse/chopping technique, you can get an even chop without the danger of overprocessing. Check the texture frequently by looking through the cover of the work bowl. If you want a finer chop, press and release the OFF/PULSE lever until you achieve the desired texture. Onions and other food with a high water content will quickly end up as a purée unless examined through the work bowl after each pulse to make sure it is not overprocessed.

Try chopping other food, like meat for hamburger or sausage. Then make mayonnaise, pastry or bread, as described in the recipes in this book. To obtain consistent results:

- Be sure all the pieces you add to the bowl are about the same size.
- Be sure the amount you process is no larger than recommended (see table inside front cover).

REMOVING PROCESSED FOOD

Before you do anything, wait for the blade to stop spinning.

When it does, remove the cover first. You can remove the cover and pusher assembly in one operation. Hold the pusher assembly with your fingers away from the descending tabs and turn it clockwise. Lift it off, and the cover will come with it.

Never try to remove the cover and the work bowl together; this can damage the work bowl.

Remove the bowl from the base of the machine before removing the blade. This creates a seal to prevent food from leaking. Turn the bowl clockwise to unlock it from the base and lift it straight up to remove it.

A locking device prevents heavy dough from driving the blade up the motor shaft. If the blade holds the bowl locked when the motor stops, move the handle of the bowl rapidly back and forth – first clockwise, then counterclockwise.

To prevent the blade from falling out of the work bowl onto your hand, remove the metal blade before tilting the bowl, using a spatula to scrape off any food sticking to it. Or insert your finger through the hole in the bottom of the work bowl, gripping the

blade from the bottom, and grip the outside of the work bowl with your thumb. Or hold the blade in place with your finger or a spatula while pouring out processed food. Be sure hands are dry.

TECHNIQUES FOR CHOPPING AND PURÉEING

To chop raw fruits and vegetables:

First, cut the food into 1-inch (2.5 cm) pieces. You get a more even chop when all pieces are about the same size.

Put no more than the recommended amount of food into the work bowl (see Capacity Chart, page 2). Lock the cover in place. Press the OFF/PULSE lever at the rate of 1 second on, 1 second off until the food is coarsely chopped. Then hold down the OFF/PULSE lever, letting the machine run continuously until the food is chopped. Check frequently to avoid overprocessing. Use the spatula to scrape down any pieces that stick to the sides.

To purée fruit and cooked vegetables:

First, cut the food into 1-inch (2.5 cm) pieces. You get a smoother purée faster when all pieces are about equal in size. Put no more than the recommended amount of food in the work bowl (see Capacity Chart, page 2). Lock the cover in place. Pulse to chop coarsely, then press the ON lever and process continuously until the food is puréed.

NOTE: Cooked potatoes are an exception to this procedure. They develop a gluey texture when processed with the metal blade.

When making soup, you will want to purée vegetables that have cooked in liquid. Don't add the liquid to the work bowl – just the cooked vegetables; remove them with a slotted spoon. They will purée faster and smoother without liquid. Then add just enough liquid to make the purée pourable, return it to the soup and stir to combine.

Occasionally, a piece of food may become wedged between the blade and the work bowl. If this happens, unplug machine, remove cover, lift the blade out carefully and remove the wedged piece. Empty the bowl, reinsert the blade and lock the cover into place, first removing the small pusher. Press the ON lever and drop the food pieces through the small feed tube while the machine is running. After adding a cupful this way, add the remaining food to the bowl and process in the usual way.

To chop hard foods like garlic, hard cheese:

Remove the small pusher, press the ON lever and drop the food through the small feed tube while the machine is running.

Small foods like garlic can be dropped in whole. Larger foods like hard cheese should be cut into ½ to 1-inch (1.25 to 2.5 cm) pieces. This method of processing minces garlic, shallots and onions. Hard

cheese and coconut will have the same texture as if they had been hand-grated.

IMPORTANT: Never try to process cheese that is too hard to cut with a knife. You may damage the blade or the machine.

To chop parsley and other fresh herbs:

The herbs, the work bowl and the metal blade must all be thoroughly clean and dry. Remove stems from herbs. Add leaves to bowl and process until they are chopped as fine as you want. The more herbs you chop at a time, the finer chop you can obtain. If completely dry when chopped, parsley and other herbs will keep for at least 10 days, stored in an airtight bag in the refrigerator. They may be frozen for months, stored in an airtight container or bag.

To chop peel from citrus fruit or to chop sticky fruit like dates or raisins:

For citrus, remove the peel with a vegetable peeler, leaving on the white pith, which is bitter tasting. Cut the peel into lengths of 2 inches (5 cm) or less and process with $\frac{1}{2}$ cup (125 ml) of granulated sugar until finely chopped. This may take 2 minutes or longer.

For sticky fruit like dates, raisins, prunes and candied fruit, first freeze the fruit for about 10 minutes. Add to it some of the flour called for in the recipe. Use no more than 1 cup (250 ml) of flour for each cup of fruit.

To chop meat, poultry, fish and seafood:

The food should be very cold, but not frozen. Cut it into 1-inch (2.5 cm) pieces to ensure an even chop. Process no more than the recommended amount at a time (see table inside front cover). Press the OFF/PULSE lever 3 or 4 times until desired consistency at a rate of 1 second on, 1 second off. Check the texture often to avoid overprocessing. Use a spatula to scrape food from the sides of the bowl as necessary.

To purée meat, poultry, fish and seafood:

Prepare the food as described above. Pulse until it is evenly chopped, then process continuously to the desired texture. Scrape the bowl with a spatula as needed.

Remember, you control texture by the length of time you process. By varying the processing time, you can get a range of textures suitable for hamburgers, hash, stuffed peppers, rough patés or smooth mousses.

To chop nuts:

Chop no more than the recommended amount at one time. Press and release the OFF/PULSE lever and check frequently to avoid letting powdered nuts clump together in a nut butter.

When a recipe calls for flour or sugar, add some to the nuts before you chop them – about $\frac{1}{2}$ cup (125 ml) for each cup of nuts. This allows you to chop the nuts as tiny as you want without turning them into a nut butter.

You can also chop nuts with a shredding disc. The optional Fine Shredding Disc is particularly good.

To make peanut butter and other nut butters:

Process up to the recommended amount of nuts. Let the machine run continuously. After 2 or 3 minutes, the ground nuts will form a ball that will gradually smooth out. Scrape the sides of the bowl and continue processing until drops of oil are visible. Taste for consistency. The longer you process, the softer the butter will be. For chunk style, add a handful of nuts just after the ball of nut butter begins to smooth out. To make cashew butter, add a little bland vegetable oil. Processor nut butters contain no preservatives. Store in the refrigerator to keep them without separating.

To make flavoured butters, spreads and dips:

Cut room-temperature butter into tablespoon-size pieces. Chop flavoring ingredients – anchovies, cheese, herbs, etc. – fine, then process. Be sure the work bowl is clean and dry. Add small, hard ingredients like garlic and hard cheese through the feed tube while the machine is running. Next, add the butter and process until smooth. Add any liquid ingredients last, while the processor is running, and process just long enough to blend. Process ingredients for spreads and dips in the same way. They should be at room temperature and cut into 1-inch (2.5 cm) cubes, or added by tablespoonfuls.

To make mayonnaise:

The work bowl and metal blade must be clean and dry. Use one whole large egg, or the yolks from two large eggs. Mayonnaise made from yolks will be almost as thick as butter. You should be able to add $\frac{2}{3}$ cup (150 ml) of oil for each yolk or $1\frac{1}{4}$ cups (300 ml) for a whole egg.

Process the yolks or egg with salt, mustard and 2 tablespoons (30 ml) of vegetable oil for at least 30 seconds. Then, while the machine is running, pour $\frac{1}{4}$ cup (60 ml) of oil into the small pusher. After it runs through the pinhole at the bottom, remove the small pusher and slowly add the remaining oil while the machine runs. See the recipe at the back of this book.

To beat egg whites:

Use this method only for recipes that can be done almost entirely by food processor.

The work bowl and metal blade must be absolutely clean. Add 3 or more egg whites and press the ON lever. Add about $\frac{1}{2}$ teaspoon (2.5 ml) of lemon juice or vinegar for every egg white. Vinegar makes stiffer whites; its flavour is hardly detectable in cakes,

soufflés or ice creams. Continue processing until the egg whites hold their shape – about 1½ to 2½ minutes.

For the lightest, fluffiest egg whites, use the Whisk Attachment which is an optional attachment for the Classic Series 14-Cup food processor.

To whip cream:

Processor whipped cream holds its shape very well. It is good for decoration or as a topping for gingerbread, berries or other desserts. It will not whip to the light, fluffy consistency obtained by methods that beat in more air. Use the optional Whisk Attachment for the fluffiest whipped cream.

Chill the cream well before starting. Process continuously until it begins to thicken. Then add sugar as desired and continue processing, watching carefully until the cream reaches the desired consistency. For consistently reliable results, add 2 tablespoons (30 ml) of non-fat dried milk for every cup (250 ml) of cream, before whipping.

To make crumbs and crumb crusts:

Cut or break bread, crackers or cookies into pieces and put them in the work bowl. Process continuously until they reach the desired texture. For seasoned crumbs, chop the parsley or other fresh herbs with the crumbs. For buttered crumbs, process until the dry crumbs are of the desired texture, then drizzle melted butter through the small feed tube while the machine is running.

For crumb crusts, process crackers or cookies as described above. Add sugar, spices and butter, cut into pieces, as specified by your recipe. Process until well combined.

To make pastry:

This describes general procedure. A recipe giving exact proportions is at the back of this book.

Combine unbleached all-purpose flour, salt and pieces of very cold or frozen butter in the work bowl. Process to the consistency of cornmeal. While pulsing, start pouring ice water through the feed tube. Stop pulsing as soon as the dough begins to form a ball, to ensure tender, flaky pastry. Use the dough immediately or form it into a round disc about 1-inch (2.5 cm) thick. Wrap it in plastic wrap and refrigerate or freeze for later use.

To make quick breads and cakes that use baking powder and/or soda:

The most important rule for success is not to overmix after the flour is added. If the recipe calls for chopped ingredients like lemon peel or nuts, chop them first while the work bowl is clean and dry. Then set them aside until needed. (Always use sugar when chopping lemon peel.)

Put dry ingredients like flour, salt and leavening in the work bowl and process with the metal blade for

5 seconds to mix them. Remove and reserve the dry ingredients. Add the eggs and sugar to the work bowl and process to mix, letting the machine run about 1 minute. Next, add butter, which has been cut into 1-inch (2.5 cm) pieces and brought to room temperature. Let the machine run continuously for a minute, until the butter is thoroughly mixed with the sugar and eggs. Then add flavouring and liquid – vanilla, spices, cocoa, etc. Process until mixed. Add the dry ingredients to the work bowl. Process by pulsing, inspecting after each pulse. Stop pulsing as soon as the dry ingredients have almost disappeared into the batter.

Overprocessing will cause quick breads and cakes to be tough. (If your recipe calls for ingredients that are to be coarsely chopped, like raisins or nuts, add them last with the mixed dry ingredients.)

To make cake mix:

Your food processor work bowl is large enough for the preparation of an 18.5-ounce (524 g) packaged cake mix.

Insert the metal blade and add the cake mix to the work bowl. While the machine is running, add the eggs and liquid through the small feed tube and process for 5 seconds. Scrape down the side of the work bowl and process again for 1 minute for maximum volume. Do not remove the metal blade. Insert a finger into the underside of the blade from the bottom of the work bowl to hold the blade in place while emptying the batter.

Tip: After emptying cake batter or puréed soup from the work bowl, replace the bowl on the motor base. Insert the metal blade and pulse once. Centrifugal force will spin the batter off the blade onto the side of the work bowl. Remove the blade, and use the spatula to scrape any remaining batter from the bowl.

TECHNIQUES FOR KNEADING YEAST DOUGH

The Classic Series 14-Cup (3.5 L) food processor can mix and knead dough in a fraction of the time it takes to do it by hand. You will get perfect results every time if you follow these directions. NEVER TRY TO PROCESS DOUGH THAT IS TOO STIFF TO KNEAD COMFORTABLY BY HAND.

There are two general types of yeast dough.

Typical bread dough is made with a flour mix that contains at least 50% white flour. It is uniformly soft, pliable and slightly sticky when properly kneaded. It always cleans the inside of the work bowl completely when properly kneaded.

Typical sweet dough contains a higher proportion of sugar, butter and/or eggs than typical bread dough. It is rich and sticky and it does not clean the inside of the work bowl. It requires less kneading after the ingredients are mixed. Although 30 seconds is usually sufficient, 60 to 90 seconds gives better results if the machine does not slow down. Except for kneading, described below, the processing procedures are the same for both types of dough.

Machine capacity:

If a bread dough calls for more than the recommended amount of flour, mix and knead it in equal batches. Do the same for sweet doughs that call for more than 3½ cups (875 ml) of flour. Recommended maximum amount of flour is 5 cups (1.25 L) of all-purpose flour or 3 cups (750 ml) of whole-grain flour.

Installing the blade:

Make sure to always push the blade down as far as it will go on the motor shaft.

Measuring the flour:

It's best to weigh it. If you don't have a scale, or the recipe doesn't specify weight, measure by the "stir, scoop and sweep" method. Use a standard, graduated dry measure, not a cup for liquid ingredients.

With a spoon or fork, stir the flour in its container. With the dry measure, scoop up the flour so it overflows. With a spatula, knife or chopstick – being careful not to press down – sweep excess flour back into the container so the top of the measure is level.

Proofing the yeast:

The expiration date is marked on the package. To be sure your yeast is active, dissolve it in a small amount of warm liquid (about ⅓ cup [75 ml] for one package of dry yeast). If the recipe includes a sweetener like sugar or honey, add a small amount with the yeast. If no sweetener is called for, add a pinch. The yeast proofs better with it. Let the mixture stand until it foams – up to 10 minutes.

Processing dry ingredients:

Put the flour in the work bowl with all the other dry ingredients. If the recipe calls for herbs, oil or solid fats like butter, add them with the flour. Turn the machine on and let it run for about 20 seconds. (Cheese, nuts and raisins may be added with the dry ingredients or during the final kneading. To leave them almost whole, add them 5 seconds before you stop kneading. For a finer texture, add them sooner.)

Adding liquids:

All liquids should be added through the feed tube while the machine is running. Add liquid in a slow, steady stream, only as fast as dry ingredients absorb it. If liquid sloshes or splatters, stop adding it but do

not turn off machine. Wait until ingredients in bowl have mixed, then add remaining liquid slowly. Pour liquid onto dough as it passes under feed tube opening. Do not pour liquid directly onto bottom of bowl.

Follow the recipe carefully. It is important to add enough liquid to make the dough soft enough to knead. Kneading dough that is too stiff can strain the machine.

The temperature of liquids used to dissolve and activate yeast must be between 105° and 115°F (40° and 46°C). Yeast cells are not activated at temperatures lower than this and they die when exposed to temperatures higher than 130°F (54°C).

All liquids, except that used to activate yeast, should be cold, to minimize the possibility of overheating the dough. You must never knead a yeast dough to a temperature higher than 100°F (38°C). Doing so will slow or even prevent the action of the yeast.

Kneading bread dough:

Do not try to use the machine to knead dough that is too stiff to knead comfortably by hand. Doing so can strain the machine.

After the dough starts to clean the inside of the work bowl completely and forms a ball, process it for 60 seconds to knead. Stop the machine and test the dough to be sure it's properly kneaded. Typical bread dough should have a soft, pliable texture and it should feel slightly sticky. Stretch the dough with your hands to test it. If it feels hard, lumpy or uneven, continue processing until it feels uniformly soft and pliable. Make sure that the blade is firmly pressed back into place after removing the dough to test it.

Kneading dough for coffeecakes, batter bread and brioche:

Process dough for at least 30 seconds after all the ingredients are incorporated. It may not clean the inside of the work bowl. If necessary, scrape the bowl and process for 5 more seconds.

Rising:

Put the dough in a large, lightly floured plastic bag. Squeeze out all the air and close the end with a wire twist, allowing space for the dough to rise.

Or put the ball of dough in a large bowl coated with soft butter or vegetable oil. Roll the dough around to coat its entire surface. Cover it with a damp towel or a piece of oiled plastic wrap.

Let it rise in a warm, draft-free place – about 80°F (27°C). The rising time is usually about 1½ hours, but will vary from 45 minutes to several hours, depending on the type of flour and the humidity of the air. To test if the dough has risen enough, stick a finger in it. An indentation should remain. If it doesn't, let the dough rise more and test again. When it has risen enough, punch the dough down.

Making consecutive batches:

You can make several batches of bread dough in a row. The motor in the Classic Series 14-Cup Food Processor is extremely efficient. Follow the recipe for White Bread, page 26 of the Recipe Booklet.

PROBLEMS & SOLUTIONS WITH TYPICAL DOUGH

BREAD DOUGH

Blade doesn't incorporate ingredients:

Always start processor before adding liquids. Add liquid in slow, steady stream, only as fast as dry ingredients absorb it. If you hear liquid sloshing, stop adding it, but do not turn off machine. Instead, wait until ingredients in work bowl have mixed, then add remaining liquid slowly. Pour liquid onto dough as it passes under feed tube; do not pour liquid directly onto bottom of work bowl.

Blade rises in work bowl:

Blade may not have been pushed down as far as it will go before processing started.

Excessively sticky dough can cause blade to rise even though it cleans inside of work bowl. If dough feels very sticky, carefully reinsert blade and immediately add 2 tablespoons (30 ml) flour through feed tube while machine is running.

Dough doesn't clean inside of work bowl:

- Amount of dough may exceed maximum capacity of your food processor. Remove half and process in 2 batches.
- Dough may be too dry. If it feels crumbly, add water – 1 tablespoon (15 ml) at a time – while machine is running, until dough becomes moist and cleans inside of work bowl. Wait 10 seconds between additions of water.
- Dough may be too wet. While machine is running, add 1 tablespoon (15 ml) of flour. If necessary, add more – 1 tablespoon (15 ml) at a time – until dough cleans inside of work bowl and forms a ball.

Nub of dough forms on top of blade and does not become uniformly kneaded:

Stop machine, carefully remove dough, divide it into 3 pieces and redistribute them evenly in work bowl. Continue processing until dough is uniformly soft and pliable.

Dough feels tough after kneading:

Divide dough into 2 or 3 pieces and redistribute evenly in bowl. Process 10 seconds or until uniformly soft and pliable.

Soft dough or liquid leaks onto base of food processor:

Always start processor before adding liquid and add liquid only as fast as dry ingredients absorb it.

Motor stops:

- Pusher assembly may have become unlocked. Push down pusher sleeve to lock it into place and continue processing.
- Power cord may have become unplugged. Plug machine in and continue processing.
- Excessive strain may have caused motor to overheat and stop. Wait for the motor to cool off, 5–10 minutes. A safety protector in the motor prevents it from excessive overheating. If the motor stops, turn the machine off. After 5–10 minutes, divide dough into 2 batches and complete processing. Pinch dough to make sure that it is not too stiff to knead comfortably by hand. If it is, add liquid – 1 teaspoon (5 ml) at a time – until dough is sufficiently moist to clean inside of bowl.

Dough doesn't rise:

We recommend that you always test activity of yeast before using it by stirring it and at least ½ teaspoon (2.5 ml) sugar into about ⅓ cup (75 ml) warm liquid (105°F–115°F [40°C–46°C]). Within 10 minutes foam should develop, indicating yeast is active. Do not use dry yeast after expiration date on package.

Avoid killing yeast cells by dissolving yeast in too warm water or overheating dough by excessive kneading. Dissolve yeast in about ⅓ cup (75 ml) of warm liquid at 105°–115°F (40°–46°C). All other liquid should be cold.

Don't knead so long that it becomes overheated. The ideal temperature for kneaded dough is 80°F (27°C); it should never exceed 100°F (38°C).

Let dough rise in draft-free environment of about 80°–90°F (27°C–32°C).

Dough containing whole grain flour will take longer to rise than dough made of white flour only.

Baked bread is too heavy:

Next time, feel dough to be sure it is uniformly soft, pliable and slightly sticky before setting it aside to rise. Let dough fully double in bulk in bowl or bag, punch it down, then let it double again after it is shaped.

SWEET DOUGH

Motor slows down:

- Amount of dough may exceed maximum capacity of your food processor. Remove half and process in 2 batches.
- Don't process too long after all the ingredients are incorporated. These rich doughs will give you good results after only 30 seconds of kneading.

Blade doesn't incorporate ingredients:

Butter or margarine, if not melted, must be cut into tablespoon-size (15 ml) pieces before being added to work bowl.

Metal blade rises in work bowl:

Blade may not have been pushed down as far as it will go before processing started. Machine may be overloaded. Stop it, remove half of dough and process in 2 batches.

Motor stops:

See comments under "Typical Bread Dough."

Dough doesn't rise:

See comments under "Typical Bread Dough."

PREPARING FOOD FOR SLICING AND SHREDDING

Round fruits and vegetables:

Before processing onions, apples and other large, round fruits and vegetables, trim them with a knife. Cut the bottom end flat, to make the food lie stable on the disc.

Place the food in the feed tube, flat side down. Position it as far left as possible, to prevent it from tilting when being processed.

Choose fruits that are firm and not too ripe. Always remove large hard pits and seeds from fruits before processing. Seeds from citrus fruits need not be removed. You may remove the rind before slicing or shredding, or leave the rind on.

Whole peppers are an exception:

Remove the stem and cut the stem end flat. Remove the core and scoop out the seeds. Leave the end opposite the stem whole, to keep the structure stiff. This ensures round, even slices.

Large fruits like pineapple and cantaloupe:

Cut them in half and remove the seeds or core. If necessary, cut the halves into smaller pieces to fit the feed tube. Remember to cut the ends flat.

Cabbage and iceberg lettuce:

Turn the head on its side and slice off the top and bottom, leaving a center section about 3 inches (7.5 cm) deep. Remove the core and cut the center section in wedges to fit the feed tube. Remove the core from the bottom piece and cut it and the top piece into wedges to fit the feed tube. The optional 2mm or 1mm Slicing Discs are excellent for slicing cabbage for coleslaw.

If the fruit or vegetable doesn't fit:

Try inserting it from the bottom of the feed tube. The opening there is slightly larger.

Pack the feed tube for desired results:

For long slices or shreds, cut the food in feed tube widths and pack the pieces horizontally.

For small, round slices or short shreds from carrots, zucchini and other long vegetables, cut them in feed-tube heights and pack them tightly upright.

Food should fit snugly, but not so tight that it prevents the pusher from moving.

When slicing or shredding food, always use the pusher. Never put your fingers or a spatula into the feed tube.

Never push down hard on the pusher. Use light pressure for soft fruits and vegetables like bananas, mushrooms, strawberries and tomatoes, and for all cheese. Use medium pressure for most food like apples, celery, citrus fruit, potatoes and zucchini. Use firm pressure for really hard vegetables like carrots and yams.

PRACTICING SLICING AND SHREDDING

1. Insert a slicing or shredding disc, put the cover on the work bowl and insert the prepared food in the feed tube.
2. Prepare the pusher assembly. Lock the small pusher in place.
3. Slide the pusher assembly over the feed tube and push the sleeve down to lock it into place. Apply pressure to the pusher while pressing down the OFF/PULSE lever. Release the lever as soon as the food is sliced or shredded.
4. You can load the feed tube repeatedly without removing the work bowl cover. Press firmly on the tab and lift up. The pusher assembly will come off easily, leaving the cover and feed tube in place. Your other hand is free to reload the feed tube.

REMOVING SLICED OR SHREDDED FOOD

Before you do anything, wait for the disc to stop spinning. When it does, remove the cover first. Lift, and the pusher assembly and cover will come off together.

Remove the slicing or shredding disc before removing the work bowl. Place two fingers under each side of the disc and lift it straight up. Then turn the bowl clockwise to unlock it from the base and lift it straight up to remove it.

You can place the disc on top of the inverted work bowl cover, to minimize drips and spills.

TECHNIQUES FOR SLICING AND SHREDDING

Small, round fruits and vegetables:

For large berries, radishes, and mushrooms, trim the opposite ends flat with a knife. Insert the food through the feed tube, standing each piece on a flat end. You can fill the tube to about 1-inch (2.5 cm) from the top. The bottom layer gives you perfect slices for garnish.

If you want all the slices to be perfect, it's best to process one layer at a time.

Long fruits and vegetables:

Trim food like bananas, celery, and zucchini by cutting them into pieces a little shorter than the feed tube. Cut both ends flat. (Use a ruler as a guide, or the pusher assembly with the pusher pulled out as far as it will go.)

Fill the feed tube with the pieces, standing them vertically and adding enough pieces so they are solidly packed and cannot tilt sideways as they are sliced or shredded.

Small amounts of food:

Use the small feed tube and the small pusher. Remove the small pusher from the pusher assembly. Slide the pusher assembly over the feed tube and press the sleeve down to lock it into place.

Cut the food in lengths a little shorter than the feed tube. If you are slicing one or two long, thin vegetables like carrots, push them against the left. If you are slicing a few vegetables that are wide at one end and narrow at the other, like carrots, celery or scallions, cut them in half and pack in pairs, one wide end up, one narrow end up.

French-cut green beans:

Trim fresh green beans to feed-tube widths. Blanch them for 60 seconds in boiling salted water. Plunge them immediately into cold water to stop the cooking. When they are cold to the touch, drain and

dry them. Stack them in the feed tube horizontally to about 1 inch from the top. Use the slicing disc.

Be sure the small pusher is locked. Apply light pressure to the pusher and press the OFF/PULSE lever until beans are sliced.

To make long, horizontal slices of raw zucchini or carrots, use the same procedure.

Matchsticks or julienne strips:

Process the food twice – “doubleslice” it. Insert any large fruit or vegetable – potatoes, turnips, zucchini, apples – in the feed tube horizontally. Apply pressure to the pusher while pressing the OFF/PULSE lever until the food is sliced. You will get long slices. Remove the slices from the work bowl and reassemble them. Reinsert them in the feed tube, wedging them in tightly. Slice them again. You will obtain long julienne strips. With the optional Square Julienne Discs, you can make square julienne strips in one operation.

SLICING MEAT AND POULTRY

Cooked meat and poultry:

The food must be very cold. If possible, use a chunk of food just large enough to fit the feed tube. To make julienne strips of ham, bologna or luncheon meat, stack slices of them. Then roll or fold them double and stand them upright in the feed tube, wedging in as many rolls as possible. This technique works better with square or rectangular pieces than with round ones.

Uncooked meat and poultry:

Cut the food into pieces to fit the feed tube. Boned, skinned chicken breasts will usually fit when cut in half crosswise. Wrap the pieces in plastic wrap and put them in the freezer. They are ready to slice when they pass this “knife test”: they are easily pierced with the tip of a sharp knife although semi-frozen and hard to the touch. Stand them in the feed tube, cut side down, and slice them against the grain, using firm pressure on the pusher. Or lay them flat in the feed tube, as many as will fit, and slice with the grain, using firm pressure.

Frankfurters, salami and other sausages:

If the sausage is soft, freeze it until hard to the touch, but easily pierced with the tip of a sharp knife. Hard sausages need not be frozen. If the sausage is thin enough to fit in the small feed tube, use that tube. Otherwise, cut the sausage into pieces to fit the large feed tube completely. Stand the pieces vertically, packing them in tightly so they cannot tilt sideways.

SLICING AND SHREDDING CHEESE

Firm cheese like Swiss and Cheddar:

Cut the cheese into pieces to fit the feed tube. Put it in the freezer until it is semi-frozen – hard to the touch, but easily pierced with the tip of a sharp knife. Stand the pieces in the feed tube and apply light pressure to the pusher.

Type of Cheese	Chop	Shred	Slice
Soft Brie, Camembert, Mozzarella, ricotta, Liederkrantz, cottage, cream	yes	no	no
Semi-Soft blue, Fontina Bel Paese	yes	yes chill chill chill	no
Semi-Hard Cheddar, Monterey Jack, Longhorn, Swiss, Jarlsberg, Edam, Gouda, Provolone	yes	yes chill chill chill chill chill	yes chill chill chill chill chill
Hard Parmesan, Romano, Pecorino, Sapsago	yes	yes room temp	no

IMPORTANT: Never try to slice soft cheese like mozzarella or hard cheese like Parmesan. You may damage the slicing disc or the food processor itself. You can successfully shred most cheeses except soft ones. The exception is mozzarella, which shreds well if thoroughly chilled. Hard cheeses like Parmesan shred well at room temperature. Therefore, only attempt to slice or shred mozzarella when well chilled and Parmesan when at room temperature.

IF YOU HAVE A PROBLEM

Most problems with the food processor are easily solved. Here are some possible problems and their solutions.

Food is unevenly chopped:

Either you are trying to process too much food at one time, or you are running the machine continuously instead of pulsing on and off until pieces of food are no larger than ½-inch (1.25 cm) cubes.

Liquid leaks from bottom of bowl onto motor base:

Remove bowl from base as soon as you finish processing. Do not remove metal blade first. When bowl and blade are removed together, blade drops down and forms an almost perfect seal against the bowl.

Liquid leaks out between bowl and cover when machine is running:

You added too much liquid. Never use more than 3 cups (750 ml) thin, 6 cups (1.5 L) thick liquid.

The thicker the liquid, the more you can use. The figures above are for thick mixtures like pancake or cake batter.

Slices are uneven or slanted:

Pack feed tube more carefully. Maintain even pressure on pusher.

Carrots or similar food falls over in feed tube:

Cut food into enough short pieces of equal height to fill feed tube. To slice one or two pieces, use small feed tube. Cut carrots in half and insert one piece point down and the other stem down.

Sliced or shredded food piles up on one side of work bowl:

This is normal. Remove disc occasionally and even out processed food. When food gets close to bottom of disc, empty work bowl.

A few pieces of food remain on top of slicing or shredding disc:

This is normal. In most cases, you can shred more of the food by moving the large pusher up and down, allowing the piece to be shredded, or by repositioning the piece in the feed tube and reshredding it.

Soft cheese, like mozzarella, spreads out and collects on top of shredding disc:

The cheese was not cold enough, or the pressure on the pusher was too great. To shred soft cheese, do not push on the pusher, but let the cheese go through by itself. Tap on the pusher to guide it through.

SOME TECHNICAL DATA

The motor in your food processor operates on standard line operating current. The appropriate voltage and frequency for your machine are shown on a label under the base.

An automatic, temperature-controlled circuit breaker in the motor ensures complete protection against motor burnout. If the processor runs for an exceptionally long time when chopping, mixing or kneading a thick or heavy mixture in successive

batches, the motor may overheat. If this happens, the processor will stop. Turn it off and wait for the motor to cool off before proceeding. It will usually cool off within 10 minutes. In extreme cases, it could take an hour.

Safety switches prevent the machine from operating when the work bowl or the cover is not locked into position. The motor stops within seconds when the motor is turned off, and a fast-stop circuit stops it instantly when the pusher assembly is unlocked.

CLEANING AND MAINTENANCE

Keep your Classic Series 14-Cup Food Processor ready to use on a kitchen counter. When it's not being used, leave it unplugged.

Store the blade and discs as you would sharp knives – out of the reach of children. The Disc and Blade Holders, optional accessories, offer safe and convenient storage.

All parts except for the motor base are dishwasher safe, and we recommend washing them in the dishwasher. Insert the work bowl upside down. Remember where you place the sharp blade and discs, and unload the dishwasher carefully.

To simplify cleaning, rinse the work bowl, cover, pusher assembly and blade or disc immediately after use so food won't dry on them. Openings at the bottom of the large pusher provide drainage and make cleaning easy. If food lodges in the pusher, remove it by running water through or by using a bottle brush.

If you wash the blade and discs by hand, do it carefully. Avoid leaving them in soapy water where they may disappear from sight. To clean the metal blade, fill the work bowl with soapy water, hold the blade by its plastic center and move it rapidly up and down on the center shaft of the bowl. Use of a spray attachment is also effective. If necessary, use a brush.

The work bowl is made of a plastic, which is shatter resistant and heat resistant. It should not be placed in a microwave oven.

Chopping certain foods may scratch or cloud the work bowl. Among them are ice, whole spices and oils like wintergreen. If you like to prepare your own spice blends, you may want to keep a second bowl just for that purpose.

The base housing is made of a tough plastic with high-impact resistance. Its smooth surface will look new for years. Keep a sponge handy as you work and wipe spills from the base.

Four rubber feet on the underside keep the base from moving on most work surfaces when the machine is processing heavy loads. If the feet leave spots on the counter, spray them with a spot

remover and wipe with a damp sponge. If any trace of the spot remains, repeat the procedure and wipe the area with a damp sponge and non-abrasive cleaning powder.

To clean the inside of the detachable stem, slide the stem release bottom on the side up as far as it will go and hold it there as you run water through the stem.

IMPORTANT: Never store the blade or discs on the motor shaft. The blade or discs should not be placed on the shaft except when the processor is about to be used. Any other servicing should be performed by an authorized service representative.

MAINTENANCE: Any other servicing should be performed by an authorized service representative.

FOR YOUR SAFETY

Like all powerful electrical appliances, a Classic Series 14-Cup Food Processor should be handled with care. Follow these guidelines to protect you and your family from misuse that could cause injury.

- Handle metal blade and discs carefully. Their cutting edges are very sharp.
- Always place disc on flat, stable surface before connecting detachable stem.
- Never put blade or disc on motor shaft until work bowl is locked in place.
- Always be sure that blade or disc is down on motor shaft as far as it will go.
- Always insert metal blade in work bowl before putting ingredients in bowl.
- When slicing or shredding food, always use pusher. Never put your fingers or spatula into feed tube.
- Always wait for blade or disc to stop spinning before you remove pusher assembly or cover from work bowl.
- Always remove work bowl from base of machine before you remove metal blade.
- Be careful to prevent metal blade from falling out of work bowl when emptying bowl. Remove it before tilting bowl, or hold it in place with your finger, a spatula or a spoon.
- Do not use pusher assembly if sleeve becomes detached from pusher. Call Cuisinart Consumer Service immediately. Our toll-free number is listed in the warranty.

WARRANTY

LIMITED 5-YEAR MOTOR WARRANTY

LIMITED THREE-YEAR WARRANTY

We warrant that this Cuisinart product will be free of defects in materials or workmanship under normal home use for 3 years from the date of original purchase. This warranty covers manufacturer's defects including mechanical and electrical defects. It does not cover damage from consumer abuse, unauthorized repairs or modifications, theft, misuse, or damage due to transportation or environmental conditions. Products with removed or altered identification numbers will not be covered.

This warranty is not available to retailers or other commercial purchasers or owners. If your Cuisinart product should prove to be defective within the warranty period, we will repair it or replace it if necessary. For warranty purposes, please register your product online at www.cuisinart.ca to facilitate verification of the date of original purchase and keep your original receipt for the duration of the limited warranty. This warranty excludes damage caused by accident, misuse or abuse, including damage caused by overheating, and it does not apply to scratches, stains, discolouration or other damage to external or internal surfaces that does not impair the functional utility of the product. This warranty also expressly excludes all incidental or consequential damages.

Your Cuisinart product has been manufactured to the strictest specifications and has been designed for use only in 120 volt outlets and only with authorized accessories and replacement parts. This warranty expressly excludes any defects or damages caused by attempted use of this unit with a converter, as well as use with accessories, replacement parts or repair service other than those authorized by Cuisinart.

If the appliance should become defective within the warranty period, do not return the appliance to the store. Please contact our Customer Service Centre:

Toll-free phone number:

1-800-472-7606

Address:

Cuisinart Canada
100 Conair Parkway
Woodbridge, Ont. L4H 0L2

Email:

consumer_Canada@conair.com

Model:

DFP-14NC SERIES

To facilitate the speed and accuracy of your return, please enclose:

- \$10.00 for shipping and handling of the product (cheque or money order)
- Return address and phone number
- Description of the product defect
- Product date code*/copy of original proof of purchase
- Any other information pertinent to the product's return

* Product date code can be found on the underside of the base of the product. The product date code is a 4 or 5 digit number. Example, 90630 would designate year, month & day (2009, June 30th).

Note: We recommend you use a traceable, insured delivery service for added protection. Cuisinart will not be held responsible for in-transit damage or for packages that are not delivered to us.

To order replacement parts or accessories, call our Customer Service Centre at 1-800-472-7606. For more information, please visit our website at www.cuisinart.ca.

Cuisinart®



Coffeemakers



Blenders



Juicers



Cookware



Tools and
Gadgets

Cuisinart™ offers an extensive assortment of top quality products to make life in the kitchen easier than ever. Try some of our other countertop appliances and cookware, and Savor the Good Life®.

www.cuisinart.ca

©2017 Cuisinart Canada
100 Conair Parkway,
Woodbridge, ON L4H 0L2

Printed in China

17CC030011

Trademarks or service marks of third parties referred to herein are the trademarks or service marks of their respective owners.

IB-5370-CAN