

Cuisinart®

INSTRUCTION AND RECIPE BOOKLET



Cuisinart® Elemental™ 13-Cup Food Processor with Dicing

FP-13DC Series

For your safety and continued enjoyment of this product, always read the instruction book carefully before using.













RECOMMENDED MAXIMUM WORK BOWL CAPACITY

FOOD	CAPACITY
Sliced or shredded fruit, vegetable or cheese	13 cups (3.1 L)
Dicing for vegetable and fruit	6 cups (1.4 L)
Chopped fruit, vegetable or cheese	6 cups (1.4 L)
Puréed fruit or vegetable	6 cups (1.4 L) cooked; 4 cups (1 L) puréed
Chopped or puréed meat, fish or seafood	2 pounds (907 g)
Thin liquid (e.g., dressings, soups, etc.)	8 cups (2 L)
Cake batter	8-inch (20 cm) cheesecake batter; 1 box [15.25 ounce (432.3 g)] cake mix
Cookie dough	5 dozen (based on average chocolate chip cookie recipe)
White bread/pizza dough	4 cups [1 L (all-purpose or bread flour)]
Nuts for nut butter	4 cups (1 L)

RECOMMENDED SMALL WORK BOWL CAPACITY

FOOD	CAPACITY
Chopped fruit, vegetable or cheese	2 cups (500 ml)
Puréed fruit or vegetable	2 cups (500 ml)
Thin liquid (e.g., dressings, soups, etc.)	2 cups (500 ml)
Nuts for nut butter	1 cup (250 ml)

ACCESSORIES

FUNCTION	ACCESSORY	RESULTS
Dice		
Shred		
Slice		
Small Chop		
Large Chop		
Dough		

IMPORTANT UNPACKING INSTRUCTIONS

This package contains a Cuisinart® Elemental™ 13-Cup (3.1 L) Food Processor with Dicing and accessories:

Large 13-cup (3.1 L) work bowl, small 4.5-cup (1.1 L) work bowl, work bowl cover with multiple feed tubes with interlock, accessory storage case, dicing kit and instruction/recipe book.

CAUTION: THE CUTTING TOOLS HAVE VERY SHARP EDGES.

To avoid injury when unpacking the parts, please follow these instructions.

1. Place the box on a low table or on the floor next to the kitchen counter where you intend to keep the food processor. Be sure the box is right side up.
2. Open top flaps – there will be a rectangular block of packing material that holds the processor parts, each fitted into a cavity.
3. Remove the instruction/recipe book.
4. Lift out the packing material.
5. Remove the base, the 13- and 4.5 cup (3.1 L and 1.1 L) work bowls, and place it on the counter or table. Assemble the work bowls on the base by placing them over the shaft using the handle to turn the work bowl clockwise to lock it.

6. Always read the Assembly Instructions thoroughly before using your food processor.
7. When ready to use your machine, unlock the accessory storage case, lift the cover and remove the clamshell to access the small metal chopping/mixing blade, dough blade, large metal chopping/mixing blade, stem adapter, adjustable slicing disc, and reversible shredding disc, are each in a cavity. **CAREFULLY REMOVE THE METAL CHOPPING/MIXING BLADE BY GRASPING THE CENTER HUB AND LIFTING IT STRAIGHT UP. NEVER TOUCH THE BLADES, AS THEY ARE RAZOR SHARP. CAREFULLY REMOVE THE ADJUSTABLE SLICING DISC BY USING THE PLASTIC HUB. DO NOT TOUCH THE BLADE, IT IS VERY SHARP.**

Carefully remove the slicing disc and shredding disc by using the plastic hub.

Remember to lock the parts in the storage case when not in use.

8. Save the shipping cartons and plastic foam blocks. You will find them very useful if you need to repack the processor for moving or other shipment. **NOTE:** We recommend that you visit our website, www.cuisinart.ca for a fast, efficient way to complete your product registration.

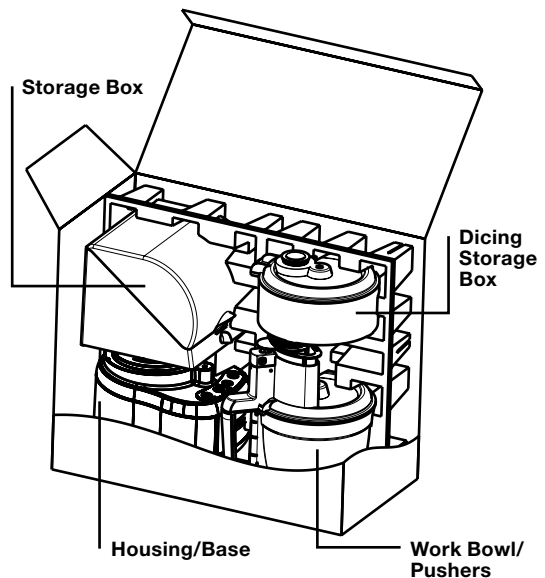
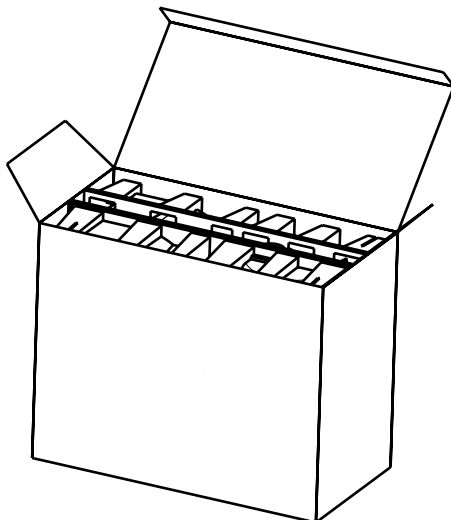

IMPORTANT SAFEGUARDS

Always follow these safety precautions when using this appliance.

Getting Ready

1. Read all instructions.
2. **Blades and discs are sharp.** Handle them carefully.
3. **Always unplug from outlet when not in use, before putting on or taking off parts, before removing food and before cleaning. To unplug, grasp plug and pull from electrical outlet. Never pull cord.**
4. Do not use outdoors.
5. Do not let cord hang over edge of table or counter, or touch hot surfaces.
6. Do not operate any appliance with a damaged cord or plug, or after appliance has been dropped or damaged in any way. Return appliance to the nearest authorized service facility for examination, repair or electrical or mechanical adjustment.

Operation

1. Keep hands as well as spatulas and other utensils away from moving blades or discs while processing food to prevent the possibility of severe personal injury or damage to food processor. A plastic scraper may be used, but only when the food processor motor is stopped.
2. Avoid coming into contact with moving parts. Never push food down by hand when slicing or shredding. Always use pusher.
3. Make sure motor has completely stopped before removing cover. (If machine does not stop within 4 seconds after you remove the bowl cover assembly, call 1-800-472-7606 for assistance. Do not use the machine.)
4. Never store any blade or disc on motor shaft. To reduce the risk of injury, no blade or disc should be placed on the shaft except when the bowl is properly locked in place and the processor is in use. Store blades and discs out of reach of children.
5. Be sure cover and feed tube are securely locked in place before operating food processor.
6. Never try to override or tamper with cover interlock mechanism.

Cleaning

1. To protect against risk of electrical shock, do not put base in water or other liquids.

General

1. This appliance should not be used by or near children or individuals with certain disabilities.
2. Do not operate this, or any other motor-driven appliance, while under the influence of alcohol or other substances that affect your reaction time or perception.
3. This food processor is cETL listed for household use. Use it only for food preparation as described in the accompanying recipe and instruction book. Do not use this appliance for anything but its intended use.
4. The use of attachments not recommended or sold by Cuisinart may cause fire, electrical shock or personal injury, or damage to your food processor.
5. To avoid possible malfunction of work bowl switch, never store processor with cover assembly in locked position.
6. Maximum rating of 550 watts is based on shredding disc, which the draws greatest current. Other recommended attachments may draw significantly less current.
7. Do not operate your appliance in an appliance garage or under a wall cabinet. **When storing in an appliance garage, always unplug the unit from the electrical outlet.** Not doing so could create a risk of fire, especially if the appliance touches the walls of the garage or the door touches the unit as it closes.

NOTICE: This appliance has a plastic case, it has a polarized plug (one blade is wider than the other). As a safety feature, this plug will fit in a polarized outlet only one way. If the plug does not fit fully in the outlet, reverse the plug. If it still does not fit, contact a qualified electrician. Do not attempt to defeat this safety feature.

SAVE THESE INSTRUCTIONS

FOR HOUSEHOLD USE ONLY

WARNING: RISK OF FIRE OR ELECTRIC SHOCK



The lightning flash with arrowhead symbol within an equilateral triangle is intended to alert the user to the presence of uninsulated, dangerous voltage within the product's enclosure that may be of sufficient magnitude to constitute a risk of fire or electric shock to persons.



The exclamation point within an equilateral triangle is intended to alert the user to the presence of important operating and maintenance (servicing) instructions in the literature accompanying appliance.

NOTICE

This appliance has a polarized plug (one blade is wider than the other). To reduce the risk of electric shock, this plug will fit into a polarized outlet only one way. If the plug does not fit fully into the outlet, reverse the plug. If it still does not fit, contact a qualified electrician. Do not modify the plug in any way.

CONTENTS

Important Unpacking Instructions.....	3
Important Safeguards.....	4
Features and Benefits	6-7
Accessory Storage Cases.....	8
Assembly Instructions	9
Chopping/Mixing Blades	10
Slicing/Shredding Discs.....	11
Dough Blade.....	13
Dicing	14
Cleaning, Storage and Maintenance.....	16
For Your Safety.....	16
Technical Data.....	17
Troubleshooting.....	17
Recipes.....	20-62
Warranty Information.....	64



WARNING

**RISK OF FIRE OR ELECTRIC SHOCK
DO NOT OPEN**



**WARNING: TO REDUCE THE RISK OF FIRE OR ELECTRIC SHOCK,
DO NOT REMOVE COVER (OR BACK)
NO USER-SERVICEABLE PARTS INSIDE
REPAIR SHOULD BE DONE BY AUTHORIZED SERVICE PERSONNEL ONLY**

FEATURES AND BENEFITS

1. 3-Part Pusher Assembly

A small pusher (1a) sits inside the medium pusher (1b), which sits inside the large pusher (1c), allowing you to accommodate ingredients of all sizes. The large pusher lock can be pulled out to lock the large pusher, and pushed in to unlock it. This feature should be used when processing heavy loads or dicing.

2. Work Bowl Cover with Supreme® Wide-Mouth Feed Tube

Cover features SealTight™ Advantage feature, allowing maximum bowl capacity during processing and pouring. Exclusive feed tube accommodates larger ingredients and saves time precutting.

3. Small 4½-Cup [1.1 L (3a)] and Large 13-Cup [3.1 L (3b)] Work Bowls

Designed for maximum versatility, select the appropriate work bowl for the task.

4. Touchpad Control Panel

These easy-to-clean buttons feature High, Low, Off and Pulse options for every food processing function.

5. Housing Base and Motor

The heavy-duty base houses a powerful 550-watt motor and vertical motor shaft that processes a variety of recipes without slowing down.

6. Small Chopping/Mixing Blade

The small stainless steel blade chops or mixes ingredients in your small work bowl – features Cuisinart's BladeLock System.

7. Dough Blade

Designed to gently knead through all types of dough. Low speed is recommended when kneading. **NOTE:** The dough blade can only be used in the large bowl.

8. Large Chopping/Mixing Blade

This heavy-duty stainless steel blade will process a variety of food in your large work bowl. The BladeLock System keeps the blade in place to provide optimal ease when pouring. **NOTE:** Large bowl has a sealed drive system that eliminates any leaks.

9. Adjustable Slicing Disc

The versatile 7-in-1 disc allows for thin to thick slices with 1mm to 7mm indicators. This disc may be used only in the large bowl.

10. Reversible Shredding Disc

Provides the option of either fine or medium shredding for optimal results. This disc may be used only in the large bowl.

11. Stem Adapter

This user-friendly tool easily attaches to either disc, small chopping/mixing blade or dicing grid and blade to engage the motor shaft.

12. Accessory Storage Case

This convenient storage case with safety lock holds all of the blades, discs and stem adapter that are included with your new food processor.

13. Dicing Kit

a. Dicing Grid Cleaning Tool

Makes quick work of removing food trapped in dicing grid.

b. Flat Work Bowl Cover with Small Pusher

This dual-function work bowl cover is also the lid of the Dicing Kit's storage case.

c. Dicing Disc

Cuts food as it is pushed through grid.

d. Dicing Grid Disc

Designed to position food to be cut into perfect squares.

e. Storage Case

Safely stores all the parts of the Dicing Kit.

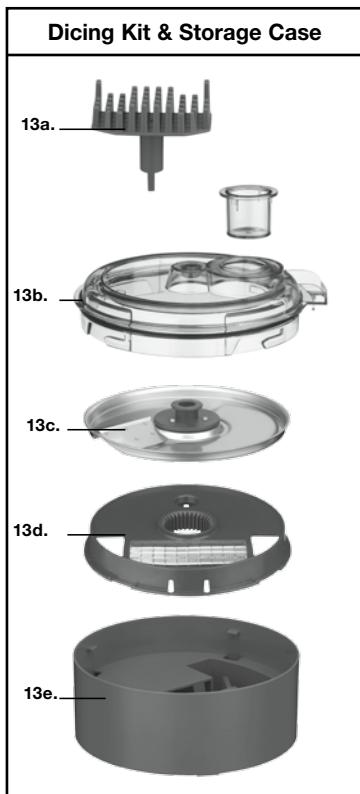
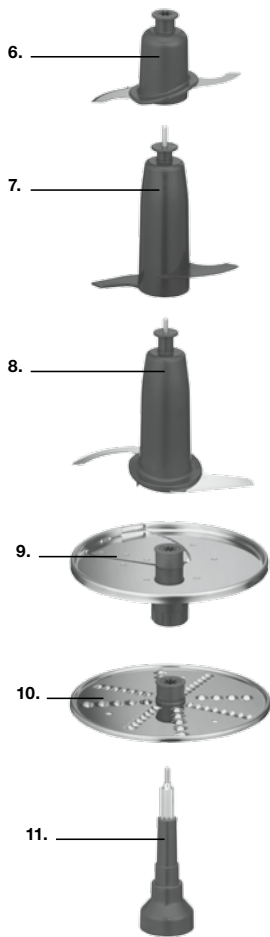
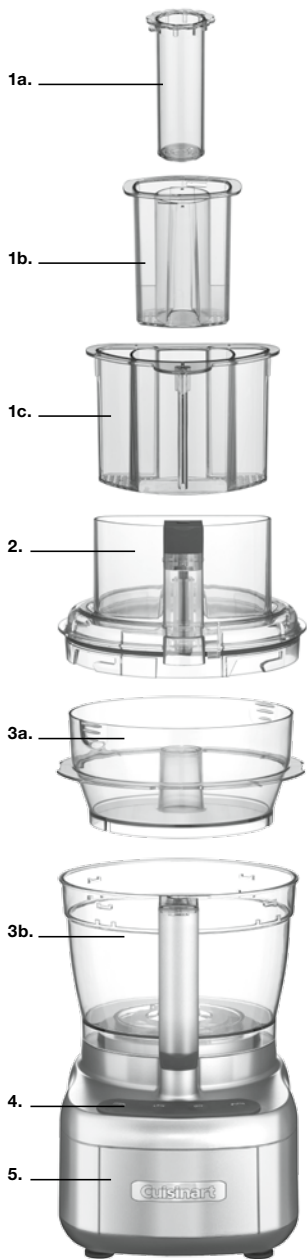

ACCESSORY STORAGE CASE

Operating the Lock

To unlock, turn counterclockwise. Gently lift up the transparent cover. Do not force the cover open when the knob is in the locked position. To lock, gently close the cover and turn the knob clockwise.

Inserting Accessories

The Accessory Storage Case holds the small chopping/mixing blade (A) on the peg in the back of the case, the dough blade (B) on the middle peg, the stem adapter (C) on the front peg, the large chopping/mixing blade (D) in the front cavity, the adjustable slicing disc (E) in the slot on the right, the reversible shredding disc (F) in the left slot.

Carefully hold discs by center hub when inserting into and removing from the storage case.

NOTE: DO NOT TOUCH METAL BLADES OR CUTTING EDGES OF DISCS. ALL ARE EXTREMELY SHARP AND CONTACT COULD CAUSE INJURY.

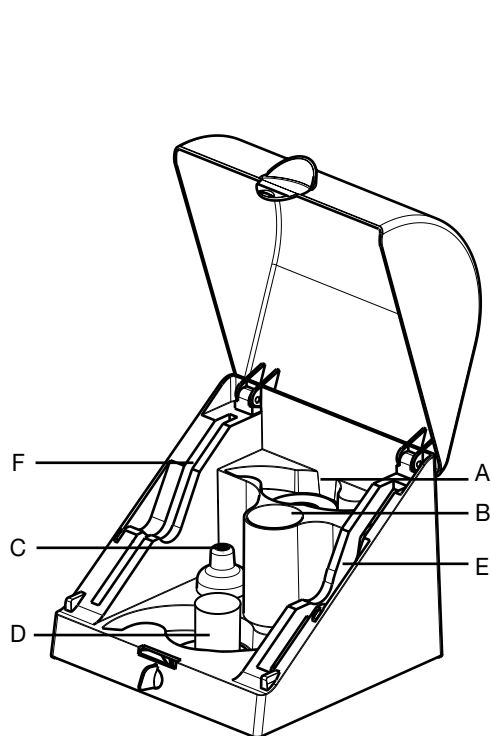

DICING KIT STORAGE CASE

Removing Parts

1. To open kit, turn the flat work bowl cover with small pusher counterclockwise and lift to remove.
2. Grasp center knob on dicing disk and carefully lift out of storage case. Set aside on a flat surface.
3. Using the openings in the top of dicing grid, grip and lift out to remove. See page 9 for assembly instructions.
4. The cleaning tool sits in a dedicated space in the base of the storage case.

NOTE: When finished dicing, wash, thoroughly dry and reverse order of directions above to return parts to storage case.

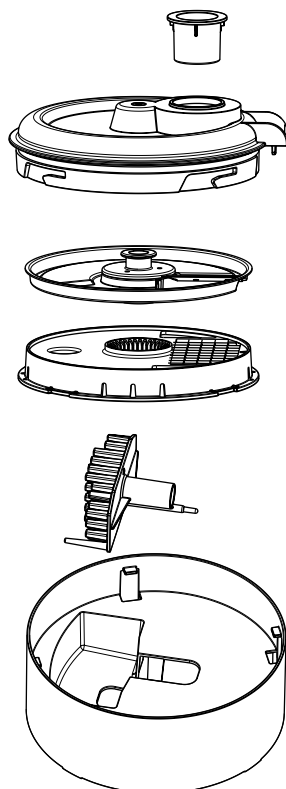

ASSEMBLY INSTRUCTIONS

Before First Use

Before using your Cuisinart® Elemental™ 13-Cup (3.1 L) Food Processor for the first time, wash all the parts (see Cleaning, Storage and Maintenance Instructions on page 16).

1. Place the food processor base on a dry, level countertop with the controls facing toward you. Do not plug the unit in until it is fully assembled.

Note: To use the small bowl, it must be nested in the large bowl with the stem adapter in place for operation.

2. Place the large work bowl on the base and use the handle to turn the bowl counterclockwise to lock it into place.
3. To use the small work bowl, first attach the large work bowl to the base. Place the stem adapter onto the shaft, then lower the small work bowl over the adapter and into the large bowl. Place your fingers in the recesses of the small bowl and turn slightly to secure in place.

Large Bowl & Accessories

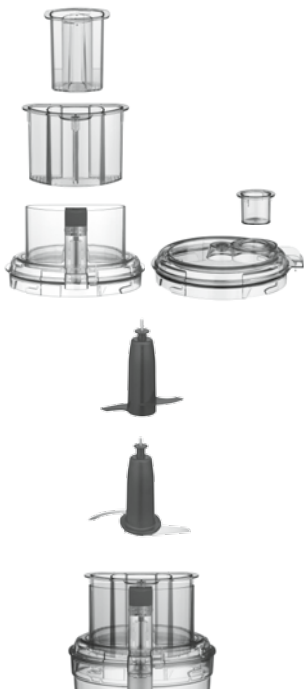

Small Bowl & Accessories

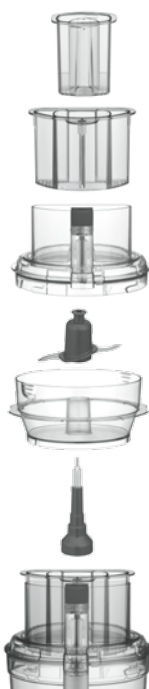

Shredding & Slicing Accessories



Dicing Kit & Accessories



Main Work Bowl Cover Operation

1. Place the lid over the work bowl with the feed-tube assembly shifted slightly to the right of the handle. Be sure to assemble the hub pin into the center of the lid.
2. Once the cover is fully seated, rotate the cover to the left (clockwise) to engage the lid locking mechanism and interlock.
3. To remove the lid, rotate the lid approximately $\frac{1}{12}$ th of a turn to the right to disengage the interlock and locking mechanism.



before mixing batter for a cake in the large work bowl. Or emulsify dressing before shredding broccoli, carrots and cabbage for vegetable slaw. Chopping certain foods may scratch or cloud the work bowl; this will not affect the functionality of your work bowl.

MACHINE CONTROLS

High and Low Control Buttons

The High and Low controls are buttons that allow the machine to run until Off is selected.

1. Properly assemble the machine.
2. Add ingredients to the work bowl, either through the feed tube or directly into the bowl. Lock lid into place.
3. Press the High or Low button. The motor will start.
4. Press the Off button when finished.

Pulse Button

The Pulse control is a button that allows the machine to run only while it is being pressed. This capability provides more accurate control of the duration and frequency of processing. Unless otherwise specified, a pulse should be about two seconds.

With the machine properly assembled and engaged, and ingredients in the work bowl, press the Pulse button repeatedly as needed.

CHOPPING/MIXING BLADES

Blade Operation

The BladeLock feature is designed to keep the blade in place during processing, pouring, lifting, and handling tasks — but is not permanently attached. **Handle with care. Always check to be sure the blade is securely locked before turning the bowl upside down.**

Large Blade Operation

With your large work bowl assembled on the base, grasp the large chopping/mixing blade by its hub, align it over the center of the bowl, place it onto the shaft and push down until it locks into place. Always check to be sure the blade is securely locked before turning the bowl upside down. (To remove, first take the bowl off the base and put it on a flat surface. Rest the heel of your hand on the rim of the bowl and pull up gently and carefully.)

Small Blade Operation

With the large work bowl in place on the base, place the stem adapter onto the hub in the center of the bowl. Next, put the small work bowl into the large bowl, positioning it over the adapter.

Flat Work Bowl Cover Operation

Use the Flat Cover for added convenience when your recipe calls for chopping, mixing, puréeing or kneading. It is particularly useful when you are preparing baked goods such as cakes, cookies, pies and breads.

Do not use the Flat Cover with any of the slicing or shredding discs. Use only with the metal blade or dough blade.

To Assemble the Flat Cover

Begin with the work bowl and the metal blade in place. Place the Flat Cover on the work bowl so that the **Cuisinart logo written on the cover** is face up and readable. Then turn cover **CLOCKWISE** to lock into place.

Make sure the small cap is in place before using.

To Disassemble the Flat Cover

Place one hand near the Cuisinart logo and one hand on opposite end of cover; turn cover **COUNTERCLOCKWISE**. Lift cover up and off work bowl. Do not use the Flat Cover with any of the slicing or shredding discs. Use only with the metal blade or dough blade.

Work Bowls

The two nested work bowls offer versatile food processing options and save you time by minimizing cleanup. Use only the small work bowl when processing smaller quantities. Optimize efficiency when making recipes that require multiple bowls, by starting with the smaller work bowl. For example, prepare a crumb topping

Grasp the small chopping/mixing blade by its hub, placing it on the stem adapter. Push down firmly to lock. (To remove, first take the bowl off the base and put it on a flat surface. Rest the heel of your hand on the rim of the bowl and pull up gently and carefully.)

Chopping (using the Chopping/Mixing Blade)

- For raw ingredients: Peel, core and/or remove seeds and pits. Food should be cut into even, ½- to 1-inch (1.25 to 2.5 cm) pieces. Foods cut into same size pieces produce the most even results.
- Pulse food in 1 to 2 second increments to chop. For the finest chop, either hold the Pulse button down or press High or Low to run the machine continuously. Watch ingredients closely to achieve desired consistency and scrape the work bowl as necessary. Low speed is recommended for making doughs and batters. High speed is recommended for most other chopping, processing and slicing/shredding tasks.

Puréeing (using the Chopping/Mixing Blade)

- To purée fresh fruits or cooked fruits/vegetables: Ingredients should be cut into 1-inch (2.5 cm) pieces; a smooth purée is best achieved when all the pieces are equal in size. Pulse to initially chop and then process High or Low until food is puréed; scrape the work bowl as necessary. Do not use this method to purée cooked white potatoes.
- To purée solids for a soup or sauce: Strain the solids from the liquid and process the solids alone. Add cooking liquid through the feed tube and process as needed.

SLICING/SHREDDING DISCS

Disc Operation

When using the large bowl, position the stem adapter onto the shaft. If using the adjustable slicing disc, use the rotating hub and indicator markings to select slicing thickness from 1 to 7 (1, thin slice) (7, thick slice). Using the plastic hub, align and insert the disc over the stem adapter.

If using the reversible shredding disc, determine whether the fine or coarse side will be used and use the plastic hub to twist into position on the stem adapter. The plastic hub may be used for removal of this disc.

NOTE: Always use the pusher when slicing or shredding. Never put your fingers in the feed tube while unit is running.

Using the Adjustable Slicing and Reversible Shredding Discs

- The slicing disc makes whole slices. It slices fruits and vegetables, cooked meat and semi-frozen raw meat. The shredding disc shreds most firm and hard cheeses. It also shreds vegetables like potatoes, carrots and zucchini.
- Always pack food in the feed tube evenly for slicing and shredding. The food will dictate the amount of pressure: Use light pressure for soft foods, medium pressure for medium foods and firm pressure for harder foods. Always process with even pressure.
- For round fruits or vegetables, slice a thick piece off base so it sits upright in feed tube. Slice to fit tube if necessary.
- For small ingredients like mushrooms, radishes or strawberries: Trim the ends so the food sits upright in the feed tube.
- When slicing or shredding cheese, be sure that it is well chilled.
- To shred leafy vegetables like lettuce or spinach: Roll leaves together and stand them up in feed tube. Process with even pressure.

Shredding & Slicing Accessories



NOTE: Always use the pusher when slicing or shredding. Never put your fingers in the feed tube while unit is running.

USER GUIDE

You can slice, shred, chop and dice a multitude of vegetables and fruits in the Cuisinart® Food Processor. What you may not know is that the food processor is the perfect tool for a number of other tasks, such as softening butter, making breadcrumbs, making baby food, etc. Here is a guide that will help you in preparing just about anything!

TIP: To avoid overflow of food, please note recommended max capacity (chart on page 2) for each type of food. All capacities are not equal.

FOOD	TOOL	SPEED	DIRECTIONS
Soft Cheeses (ricotta, cream cheese, cottage cheese, etc.)	Chopping/Mixing Blade	Low to gently mix or High to whip	Have cheese at room temperature. When applicable, cut into 1-inch (2.5 cm) pieces. Process until smooth, stopping to scrape down the sides of the bowl as needed. Perfect for making cheesecakes, dips, pasta fillings and more.
Firm Cheeses (Cheddar, Swiss, Edam, Gouda, etc.)	Slicing or Shredding Disc	High	Cheese should be well chilled before slicing/shredding. Cut to fit feed tube. Use light to medium pressure when slicing/shredding.
Hard Cheeses (Parmesan, Romano, etc.)	Chopping/Mixing Blade Slicing or Shredding Disc	Pulse and High	If using the chopping blade, cut into ½-inch (1.25 cm) pieces. Pulse to break up and then process until finely grated. This will produce a nice grated cheese. If slicing or shredding, cut to fit feed tube. Use light to medium pressure when slicing/shredding.
Baby Food	Chopping/Mixing Blade	Pulse and High	As for all fruit and vegetable purées, cut ingredients into ½- to 1-inch (1.25 to 2.5 cm) pieces. Steam ingredients until completely soft. Pulse to chop, then process until completely smooth (add steaming liquid through the feed tube when processing if necessary). Keeps frozen in ice cube trays for individual 1-ounce (28 g) portions.
Butter	Chopping/Mixing Blade Slicing or Shredding Disc	High	<i>For creaming:</i> Have butter at room temperature. Cut into 1-inch (2.5 cm) pieces. Process, scraping bowl as necessary. For compound (flavoured) butters, process flavouring ingredients, such as herbs, zest, vegetables, etc., before adding butter. <i>For shredding/slicing:</i> Freeze briefly. Use light to medium pressure to shred or slice. Shredded butter is great for preparing certain pastry doughs. Sliced butter is great for serving alongside corn on the cob or freshly made rolls.
Crumbs (Bread, Cookie, Cracker, Chip)	Chopping/Mixing Blade	Pulse and High	Break into pieces. Pulse to break up, and then process until desired consistency. This will make perfect bread/cracker/chip crumbs for coating meats and fish. Processed cookies make delicious pie and cake crusts.

FOOD	TOOL	SPEED	DIRECTIONS
Fresh Herbs	Chopping/Mixing Blade	Pulse	Wash and dry herbs thoroughly. Pulse to roughly chop. Continue pulsing until desired consistency is achieved.
Ground Meat	Chopping/Mixing Blade	Pulse	Cut meat into 1-inch (2.5 cm) pieces. Pulse to chop, about 25 long pulses, or until desired consistency is achieved. If a purée is desired, continue to process. Never chop/purée more than 2 pounds (907 g) at one time. Make sure to never process meat containing bones.
“Ice Cream”	Chopping/Mixing Blade	Pulse and High	Put frozen fruit cut into 1-inch (2.5 cm) pieces into the work bowl, with liquid (juice or milk), any desired sweeteners, such as sugar, honey, simple syrup and other flavours. Pulse to break up. Process until smooth.
Milk Shakes/ Smoothies	Chopping/Mixing Blade	Low	For milk shakes, first add ice cream. While unit is running, add milk through the feed tube until desired consistency is achieved. For smoothies, add fruit first, then add the liquid through the feed tube while unit is running.
Nuts	Chopping/Mixing Blade	Pulse and High	Pulse to chop to desired consistency. To make a nut butter, pulse to break up, and then process until smooth, stopping to scrape down as needed.
Superfine Sugar	Chopping/Mixing Blade	High	Process granulated sugar for about 1 minute until finely ground. Excellent for using in meringues and other baked goods.
Whipped Cream	Chopping/Mixing Blade	Low	Process well-chilled cream until cream begins to thicken. Add sugar as desired; process continuously until cream reaches desired consistency. This cream is dense and perfect as a whipped topping for cake or ice cream.

DOUGH BLADE

Dough Blade Operation

For use with the large bowl. Carefully place the dough blade on the shaft and push to lock into place.

Kneading

(using the Dough Blade or the Chopping/
Mixing Blade with Low Speed)

- The chopping blade is ideal for pastry doughs, while the dough blade is specifically designed for kneading yeast doughs.
- The large pusher lock is recommended to be in the locked position when kneading dough to avoid it from moving around — some vibration is still normal.
- Dough kneading should be done in the large bowl only.

Large Bowl
& Accessories



DICING

Assembling the Dicer in Work Bowl

1. With large work bowl on base, insert stem adapter.
2. Carefully place Dicing Grid onto the stem adapter with the grid positioned closest to the front of the food processor. Be sure "This Side Up" shows on top. The cutting grid should be facing with the triangle on front of the grid, aligned with the center of the work bowl handle. Dicer will not work if inserted incorrectly.

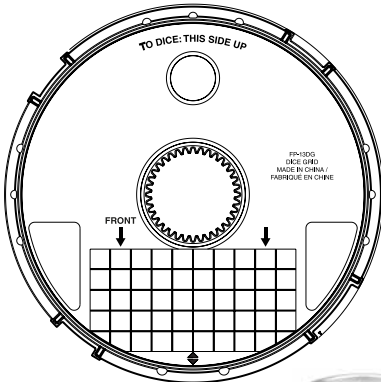

3. Carefully place dicing disk on top of grid. Push down slightly to lock into place. It should not move if positioned accurately.



Dicing Kit & Accessories



NOTE: Always use caution when handling the dicing disk; it is very sharp.

4. Follow instructions under Cover Operation to lock cover onto work bowl.

DICING GUIDE

FOOD	TOOL	SPEED	DIRECTIONS
Most Vegetables (e.g., Potato, Zucchini)	Dicing Kit	High	Peel vegetables if necessary, and trim to fit small or medium feed tube before dicing.
Soft/Very Ripe Vegetables (e.g., Ripe Tomatoes and Avocados)	Dicing Kit	Low	Peel vegetables if necessary, and trim to fit small or medium feed tube before dicing.
Most Fruits (e.g., Apples, Bananas, Strawberries)	Dicing Kit	High	Peel fruit if necessary, and trim to fit small or medium feed tube before dicing.
Soft/Very Ripe Fruits (e.g., Kiwi, Ripe Pineapple, Very Ripe Bananas)	Dicing Kit	Low	Peel fruit if necessary, and trim to fit small or medium feed tube before dicing.

*Kiwi, avocado and tomatoes are to be used on LOW setting. Always dice food in the order of soft to hard.

USING DICING KIT

- The dicing disc and grid make cubed pieces of fruit and vegetables. The recommended speed for dicing most fruits and vegetables is High. Use Low speed when dealing with very soft items such as kiwi.
- When dicing, only use the medium or small feed tube for best results. Be sure to pack single items tightly, to the left of the feed tube using consistent downward pressure.
- **Use the cleaning tool to clear the grid.** First dislodge jammed particles using the long single tooth on the handle. Then align the two long pins along the right and left of the grid. Guide the cleaner into the correct position and press down to clear the grid of food residue.

- When processing items like carrots, squash and potatoes, clean the grid every 3 to 4 times to prevent buildup.
- When large pieces of food remnants are lying between the grid and disc, use caution when cleaning off the remains by using the gaps featured to the right and left of the grid.

NOTE: We do not recommend dicing frozen foods and meats. For dicing use medium or small pusher only.

TIP: Always process foods from soft (kiwi) to hard (potato).

CLEANING, STORAGE AND MAINTENANCE

- Keep your Cuisinart® Elemental™ 13-Cup (3.1 L) Food Processor ready to use on the kitchen counter. When not in use, leave it unplugged.
- Keep the blades and discs out of reach of children.
- All parts except the housing base are dishwasher safe, and we recommend washing them in the dishwasher on the **top rack only**. Due to intense water heat, washing the work bowl, cover and accessories on the bottom rack may cause damage over time. Insert the cover with the feed tube facing up to ensure proper cleaning.
Insert the work bowl and pusher upside down for drainage. Remember to unload the dishwasher carefully wherever you have placed sharp blades and discs.
- To simplify cleaning, rinse the work bowl, cover, pusher and blade or disc immediately after use so food won't dry on them. Be sure to position the pusher upside down for drainage. If food lodges in the pusher, remove it by running water through it, or use a bottle brush.
- If you wash the blades and discs by hand, do it carefully. When handling, use the plastic hubs. Avoid leaving them in soapy water where they may disappear from sight. To clean the blades, fill the work bowl with soapy water, hold the blade by its plastic center and move it rapidly up and down on the center shaft of the bowl. Use of a spray attachment is also effective. If necessary, use a brush.
- The work bowl is made of SAN plastic with metal components. It should not be placed in a microwave oven.
- The housing base may be wiped clean with a soapy, nonabrasive material. Be sure to dry it thoroughly.
- If the feet leave spots on the counter, spray them with a spot remover and wipe with a damp sponge.
- If any trace of the spot remains, repeat the procedure and wipe the area with a damp sponge and nonabrasive cleaning powder.

IMPORTANT: Never store any blade or disc on the motor shaft. No blade or disc should be placed on the shaft except when the processor is about to be used.

MAINTENANCE: Any other servicing should be performed by an authorized service representative.

FOR YOUR SAFETY

- Like all powerful electrical appliances, a food processor should be handled with care. Follow these guidelines to protect yourself and your family from misuse that could cause injury.
- Handle and store blades and discs carefully. Their cutting edges are very sharp.
- Never put blades or discs on the motor shaft until the work bowl is locked in place.
- Always be sure that the blade or disc is down on the motor shaft as far as it will go.
- Always insert the blade in the work bowl before putting ingredients in bowl.
- When slicing or shredding, always use the pusher. Never put your fingers or spatula into feed tube.
- Always wait for the blade or disc to stop spinning before you remove the pusher assembly or cover from the work bowl.
- Always unplug the unit before removing food, cleaning or putting on or taking off parts.
- Always remove work bowl from base of machine before you remove the blade.
- Be careful to prevent the chopping/mixing blade from falling out of the work bowl when emptying the bowl. Remove it before tilting the work bowl.

TECHNICAL DATA

The motor in your food processor operates on a standard line operating current. The appropriate voltage and frequency for your machine are shown on a label on the bottom of the base.

An automatic, temperature-controlled circuit breaker in the motor ensures complete protection against motor burnout. If the processor runs for an exceptionally long time when chopping, mixing or kneading a thick or heavy mixture in successive batches, the motor may overheat. If this happens, the processor will stop. Turn it off and wait for the motor to cool before proceeding. It will usually cool within 10 minutes. In extreme cases, it could take an hour.

Safety switches prevent the machine from operating when the work bowl or the cover is not locked into position. The motor stops within seconds when the motor is turned off; and when the pusher assembly is removed, a fast-stop circuit also enables the motor to stop within seconds.

Cuisinart offers a Limited Three-Year Warranty on the entire machine.

TROUBLESHOOTING

Food Processing

- 1. Problem:** The food is unevenly processed when chopping.

Solution:

- The ingredients should be cut evenly into ½- to 1-inch (1.25 to 2.5 cm) pieces before processing.
- Process in batches to avoid overloading.

- 2. Problem:** Slices are uneven or slanted.

Solution:

- Place evenly cut food, cut side down, into the feed tube. Pack if possible. Always use the smallest feed tube possible.
- Apply even pressure on the pusher.

- 3. Problem:** Food falls over in feed tube.

Solution:

- Feed tube should be packed full for best results.

- 4. Problem:** Some food remains on top of the disc.

Solution:

- It is normal for small pieces to remain; cut remaining bits by hand and add to processed ingredients.

Dicing Kit

- 1. Problem:** Food is stuck in the grid.

Solution:

- First, unplug unit. Then, carefully reach into the large openings on either side of grid to dislodge large pieces.
- Do not use your fingers to clean the grid. **ONLY USE THE CLEANING TOOL.**
- Use the long single tooth on the cleaning tool handle to push stubborn food through.

- 2. Problem:** Pieces of food are not evenly cut.

Solution:

- Pack items closest to the left in medium or small feed tube.
- Use the small feed tube for smaller items.
- Apply even pressure when using feed tube.

Dough Kneading

1. Problem: Motor slows down.

Solution:

- Amount of dough may exceed maximum capacity of your food processor. Remove half and process in two batches.
- Dough may be too wet (see number 8). If motor speeds up, continue processing. If not, add more flour, 1 tablespoon (15 ml) at a time, until the motor speeds up. Process until dough cleans the sides of the work bowl.

2. Problem: Blade doesn't incorporate ingredients.

Solution:

- Always start the food processor before adding liquid. Add liquid in a slow, steady stream, or through the drizzle hole in the pusher, allowing the dry ingredients to absorb it. If liquid is added too quickly, wait until ingredients in the work bowl have mixed, then add remaining liquid slowly (do not turn off the machine). Pour liquid onto dough as it passes under feed tube opening; do not pour liquid directly onto bottom of the work bowl.

3. Problem: Blade rises in work bowl.

Solution:

- Excessively sticky dough can cause blade to rise. Carefully reinsert blade and immediately add 2 tablespoons (30 ml) of flour through the feed tube while the machine is running.

4. Problem: Dough doesn't clean inside of the work bowl.

Solution:

- Amount of dough may exceed maximum capacity of your food processor. Remove half and process in two batches.
- Dough may be too dry (see number 7).
- Dough may be too wet (see number 8).

5. Problem: Nub of dough forms on top of blade and does not become uniformly kneaded.

Solution:

- Stop machine, carefully remove dough, divide it into 3 pieces and redistribute them evenly in the work bowl.

6. Problem: Dough feels tough after kneading.

Solution:

- Divide dough into 2 or 3 pieces and redistribute evenly in bowl. Process 10 seconds or until uniformly soft and pliable.

7. Problem: Dough is too dry.

Solution:

- While machine is running, add water, 1 tablespoon (15 ml) at a time, until dough cleans the inside of the bowl.

8. Problem: Dough is too wet.

Solution:

- While machine is running, add flour, 1 tablespoon (15 ml) at a time, until dough cleans the inside of the bowl.

Technical

1. Problem: The motor does not start.

Solution:

- There is a safety interlock to prevent the motor from starting if it is not properly assembled. Make sure the work bowl and work bowl cover are securely locked into position.
- If the motor still will not start, check the power cord and outlet.

2. Problem: The food processor shuts off during operation.

Solution:

- The cover may have become unlocked; check to make sure it is securely in position.
- A safety protector in the motor prevents the motor from overheating, which is caused by excessive strain. Press the Off control button and wait 10 minutes to allow the food processor to cool off before resuming.

3. Problem: The motor slowed down during operation.

Solution:

- This is normal as some heavier loads (e.g., slicing/shredding cheese) may require the motor to work harder. Simply reposition the food in the feed tube and try again.
- The maximum load capacity may have been exceeded. Remove some of the ingredients and continue processing.

4. Problem: The food processor vibrated/moved around the countertop during processing.

Solution:

- Make sure the rubber feet at the bottom of the unit are clean and dry. Also make sure that the maximum load capacity is not being exceeded.
- This is normal as some heavier loads (e.g., slicing/shredding cheese) may require the motor to work harder.

WARRANTY

LIMITED THREE-YEAR WARRANTY

We warrant that this Cuisinart product will be free of defects in materials or workmanship under normal home use for 3 years from the date of original purchase. This warranty covers manufacturer's defects including mechanical and electrical defects. It does not cover damage from consumer abuse, unauthorized repairs or modifications, theft, misuse, or damage due to transportation or environmental conditions. Products with removed or altered identification numbers will not be covered.

This warranty is not available to retailers or other commercial purchasers or owners. If your Cuisinart product should prove to be defective within the warranty period, we will repair it or replace it if necessary. For warranty purposes, please register your product online at www.cuisinart.ca to facilitate verification of the date of original purchase and keep your original receipt for the duration of the limited warranty. This warranty excludes damage caused by accident, misuse or abuse, including damage caused by overheating, and it does not apply to scratches, stains, discolouration or other damage to external or internal surfaces that does not impair the functional utility of the product. This warranty also expressly excludes all incidental or consequential damages.

Your Cuisinart product has been manufactured to the strictest specifications and has been designed for use only in 120 volt outlets and only with authorized accessories and replacement parts. This warranty expressly excludes any defects or damages caused by attempted use of this unit with a converter, as well as use with accessories, replacement parts or repair service other than those authorized by Cuisinart.

If the appliance should become defective within the warranty period, do not return the appliance to the store. Please contact our Customer Service Centre:

Toll-free phone number:

1-800-472-7606

Address:

Cuisinart Canada
100 Conair Parkway
Woodbridge, ON L4H 0L2

Email:

consumer_Canada@conair.com

Model: FP-13DC Series

To facilitate the speed and accuracy of your return, please enclose:

- \$10.00 for shipping and handling of the product (cheque or money order)
- Return address and phone number
- Description of the product defect
- Product date code*/copy of original proof of purchase
- Any other information pertinent to the product's return

* Product date code can be found on the underside of the base of the product. The product date code is a 4 or 5 digit number. Example, 90630 would designate year, month & day (2009, June 30th).

Note: We recommend you use a traceable, insured delivery service for added protection.

Cuisinart will not be held responsible for in-transit damage or for packages that are not delivered to us. To order replacement parts or accessories, call our Customer Service Centre at 1-800-472-7606.

For more information, please visit our website at www.cuisinart.ca.

Cuisinart®



Food
Processors



Juicers



Coffeemakers



Cookware



Tools and
Gadgets

Cuisinart offers an extensive assortment of top quality products to make life in the kitchen easier than ever. Try some of our other countertop appliances, cookware, tools and gadgets.

www.cuisinart.ca

©2017 Cuisinart Canada

100 Conair Parkway,
Woodbridge, ON L4H 0L2

Consumer Call Centre E-mail:
Consumer_Canada@Conair.com

Printed in China

Trademarks or service marks of third parties referred to herein are the trademarks or service marks of their respective owners.

17CC030013

IB-14149-CAN